

# Opzet waterstofketen WDOD RWZI Hessenpoort

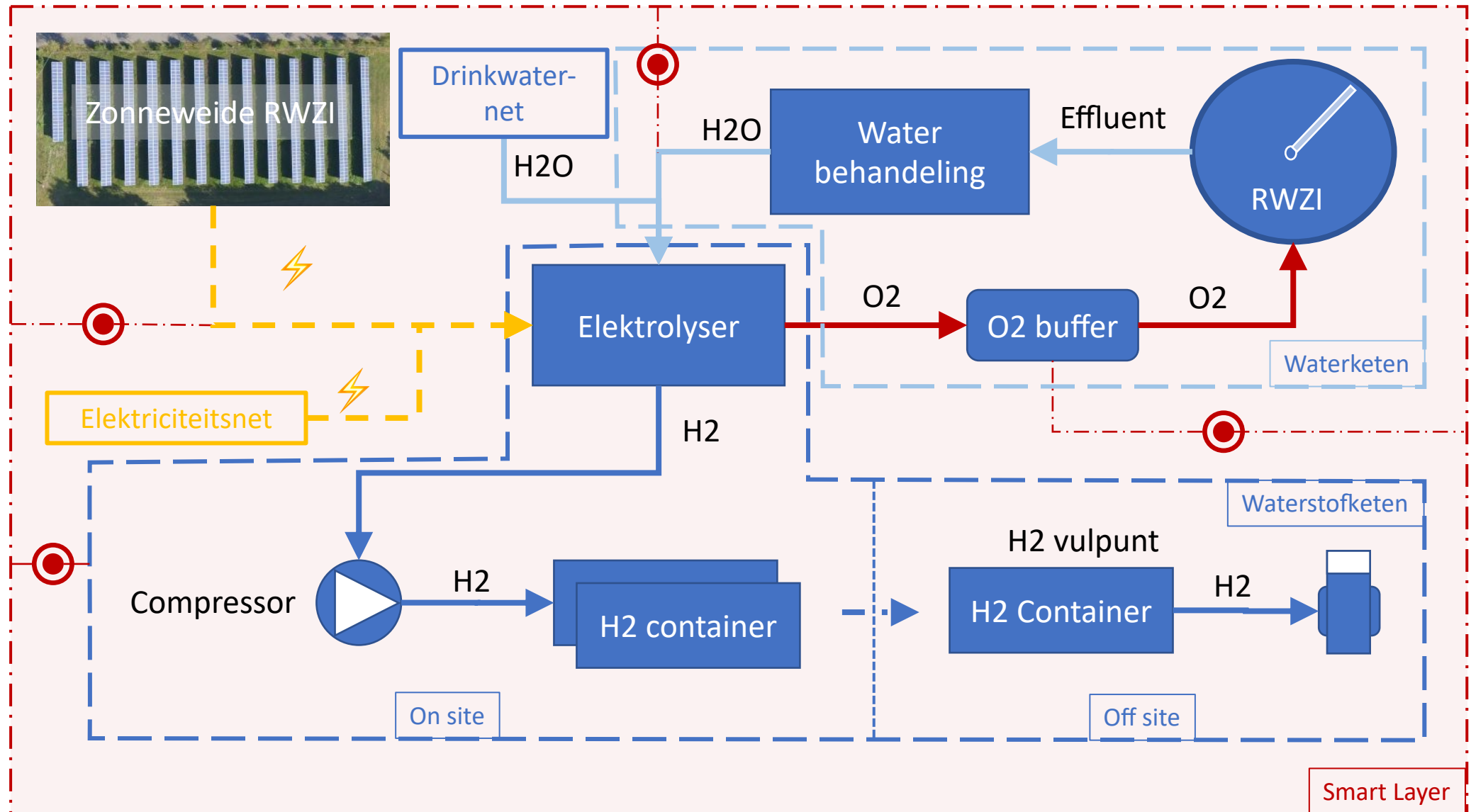

Opzet waterstofketen WDOD  
RWZI Hessenpoort

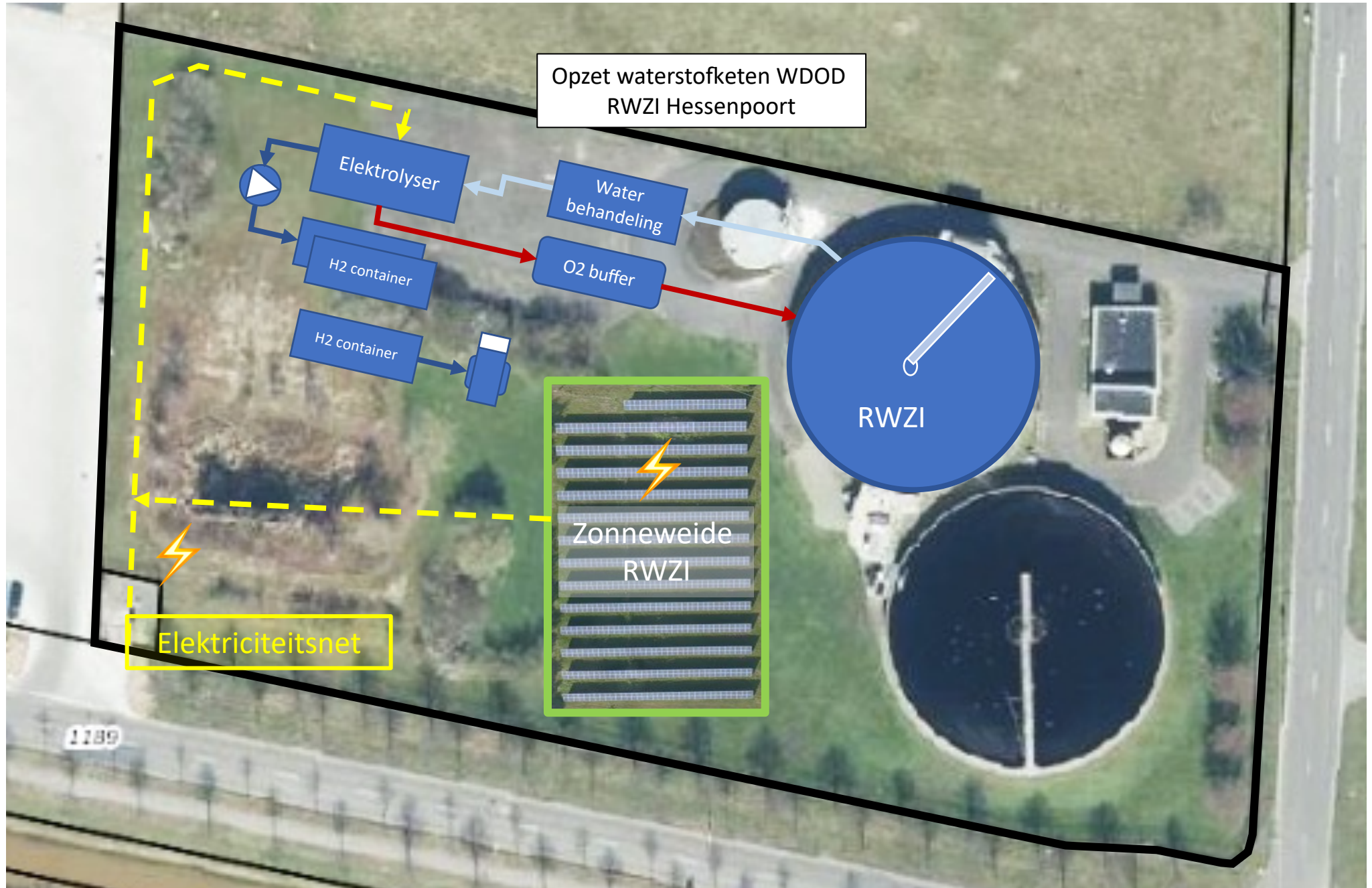

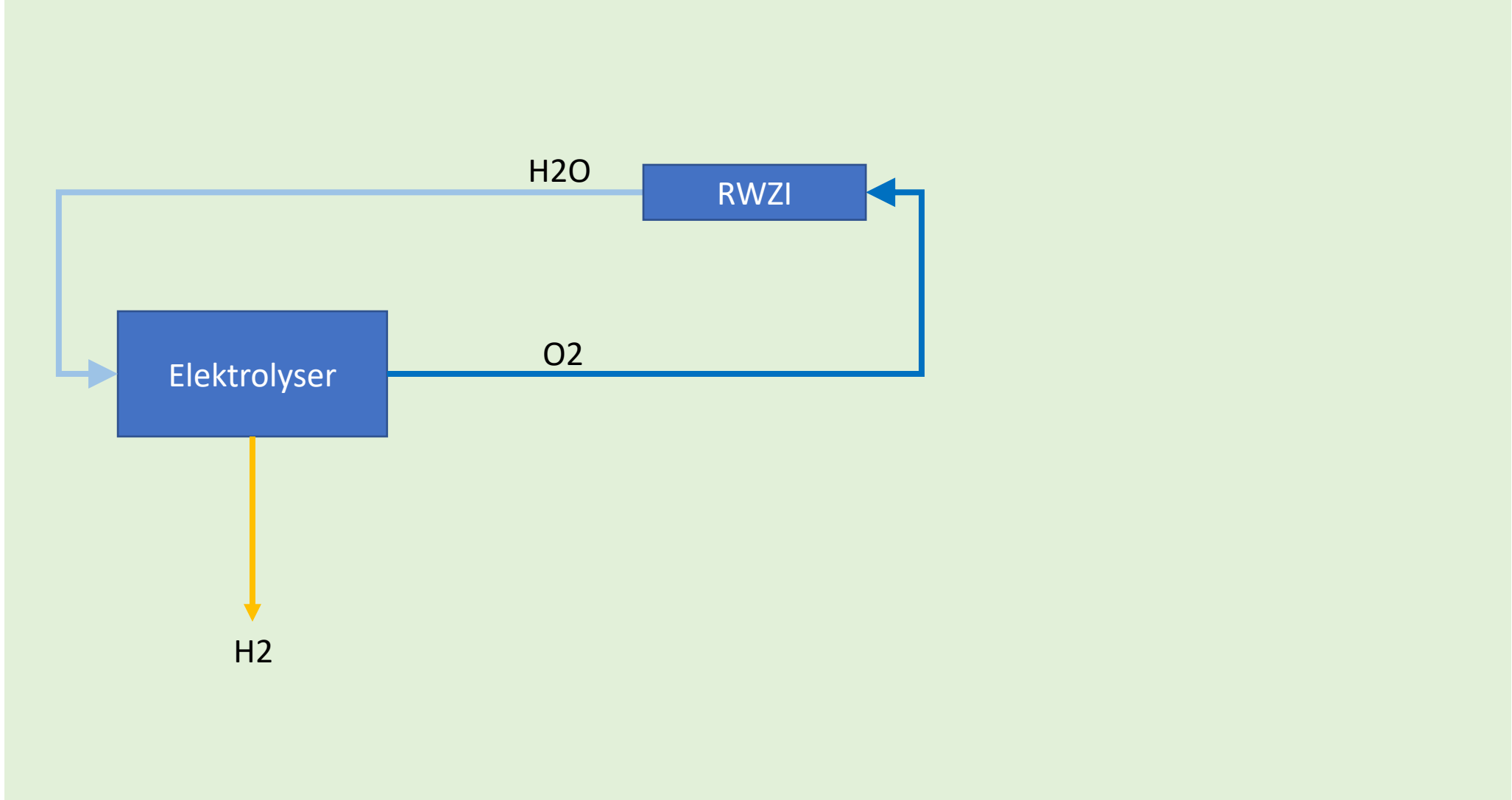

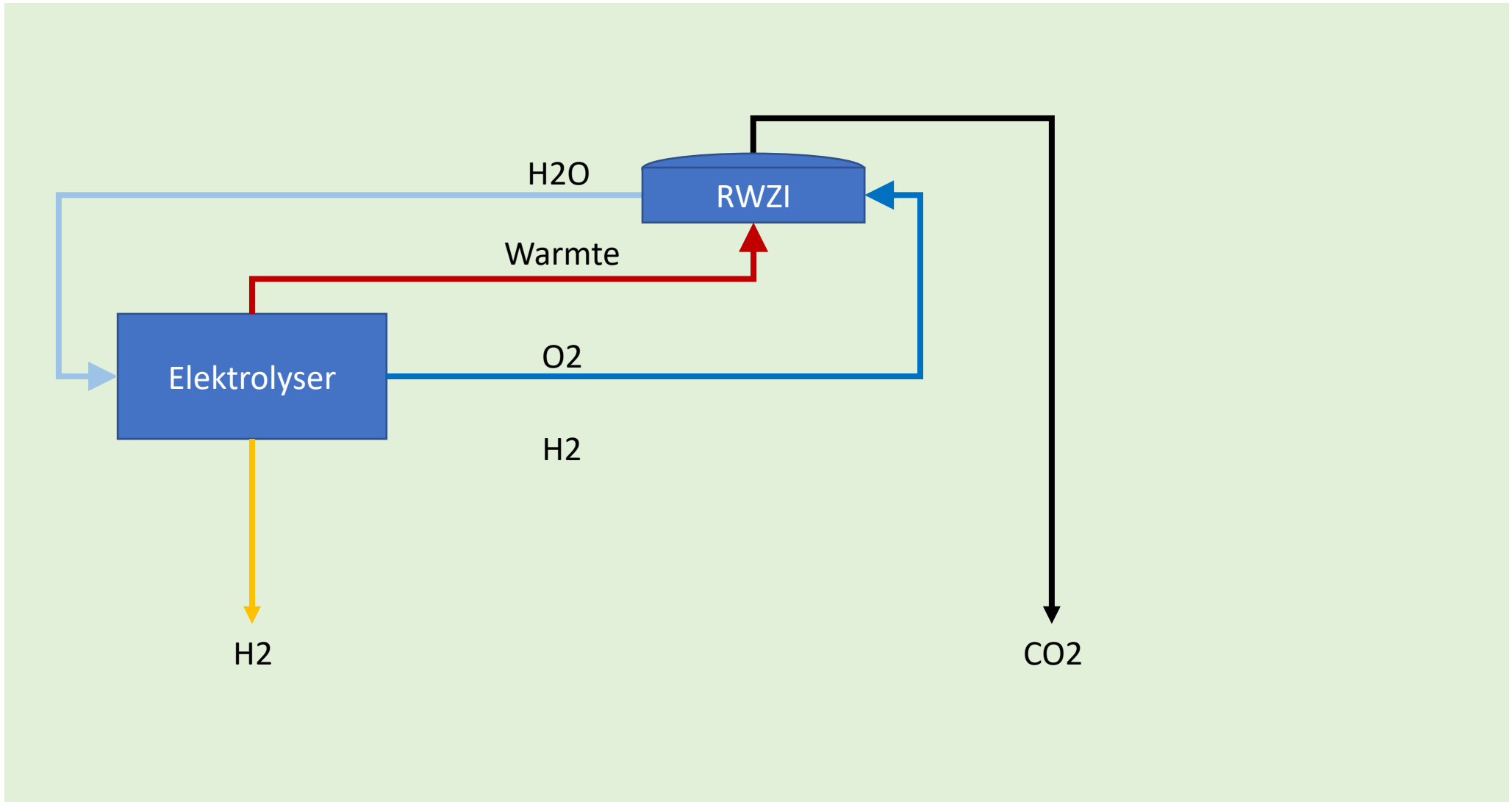

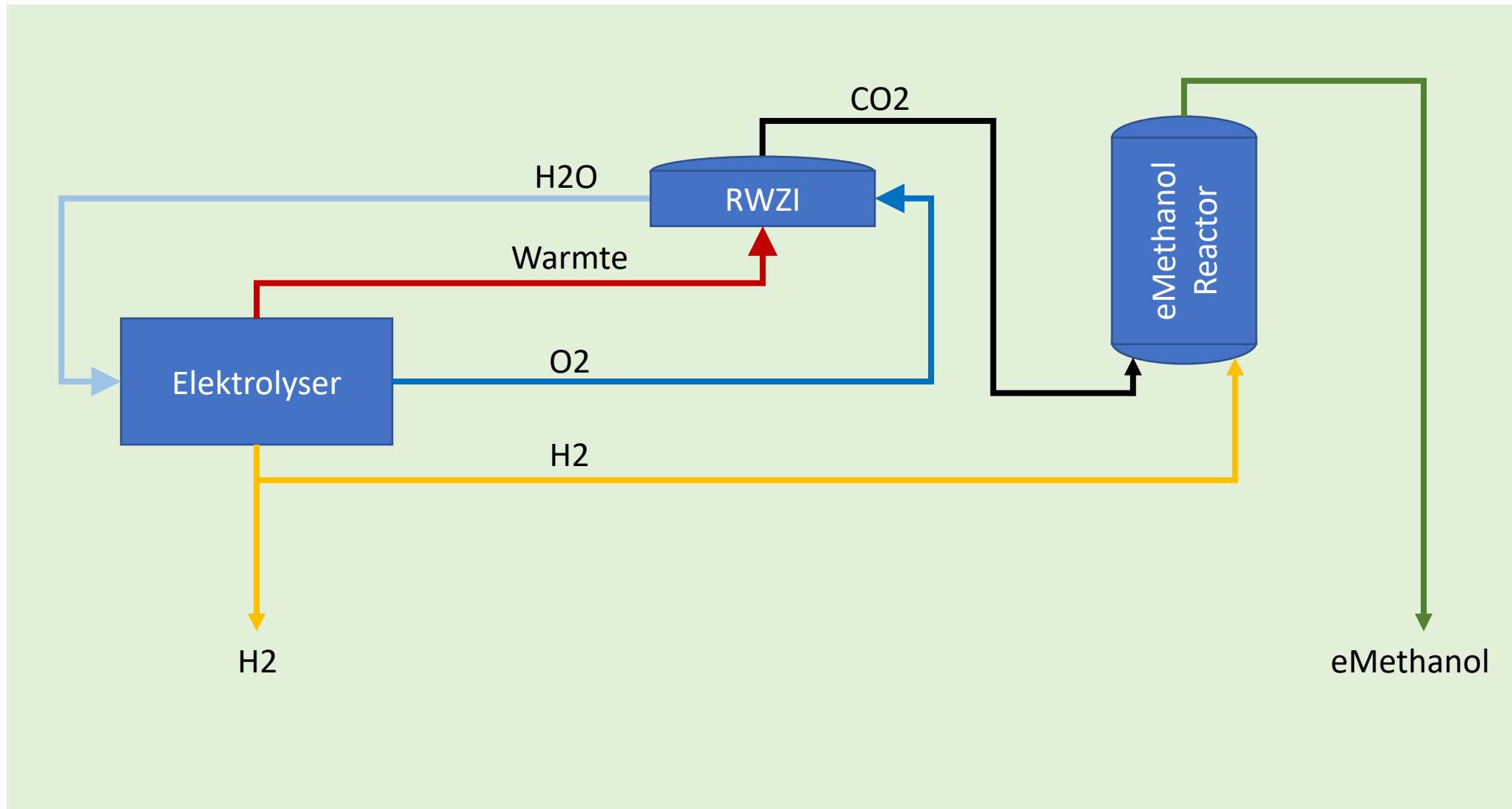

# Doorgroei en innovatiekansen RWZI configuratie (toekomstperspectief)

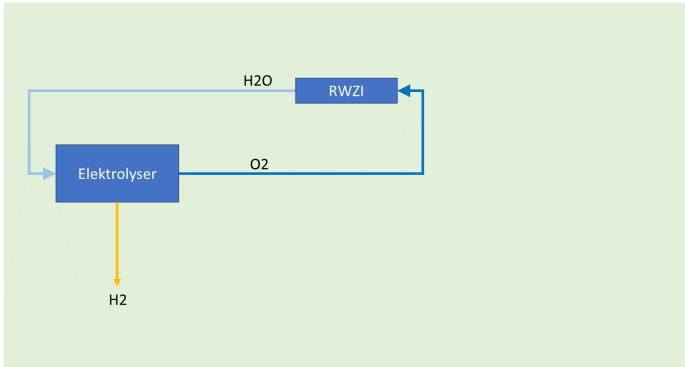

## Configuratie 1 (basis)

- H2 Productie en Levering
- O2 Recovery en Inzet RWZI

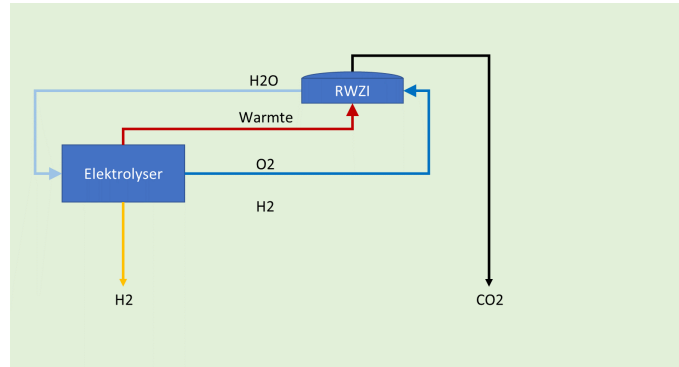

## Configuratie 2

- H2 Productie en Levering
- O2 Recovery en Inzet RWZI
- Warmte Recovery en Inzet RWZI
- CO2 Afvang en Gebruik

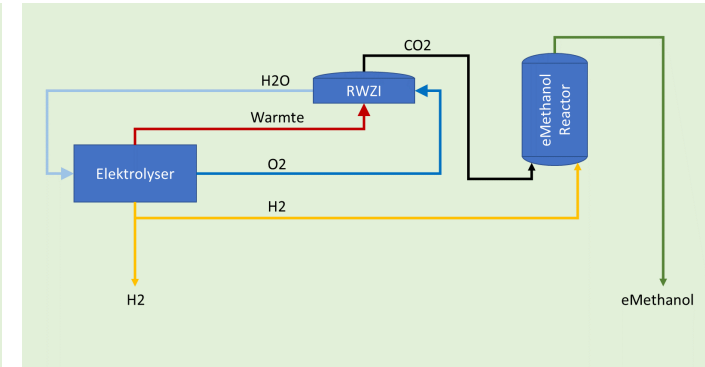

## Configuratie 3

- H2 Productie en Levering
- O2 Recovery en Inzet RWZI
- Warmte Recovery en inzet RWZI
- CO2 afvang en gebruik
- H2+CO2 Conversie eMethanol